



LED Street Light

SL50 Series

NAYAMO OPTO ELECTRONICS

Siege : Zone Industrielle Lot N°1 Ouled Salah Taher JJEL

Bureau Alger : Bt A3 N°7 Cité des 170 Logements El Achour Tel/FAX : 023 07 39 33

Tel : 213 793 84 60 39 benazouz@nayamo-optoelectronics.com

Tel: 00 33 6 08548514 sur WHATSAP debbache@nayamo-optoelectronics.com

contact@nayamo-optoelectronics.com Email: WWW.nayamo-optoelectronics.com

SL50 Street Light



Key Features

- Super slim tight design, housing has less effect to lighting effect of optic lens
- Much nicer, even, wider higher lighting effect
- With branded LEDs and driver, 150-160lm/w super high efficiency
- IP66 dual ingress protection (lens+temper glass), IK08 guaranteed
- Driver box and lighting part separately sealed, more efficient and safe
- Buckle-lock, tool-free maintenance
- Curved back, dust-free, self-cleaning
- Adjustable adaptor (± 15 degree), suit adjusting demand of installation
- TM21 service life >50000hrs

Application

Street, road, stadium, highway, bridge, sport yard, parking.

Ordering Information

SL50 Street Light

Dimension (unit: mm)

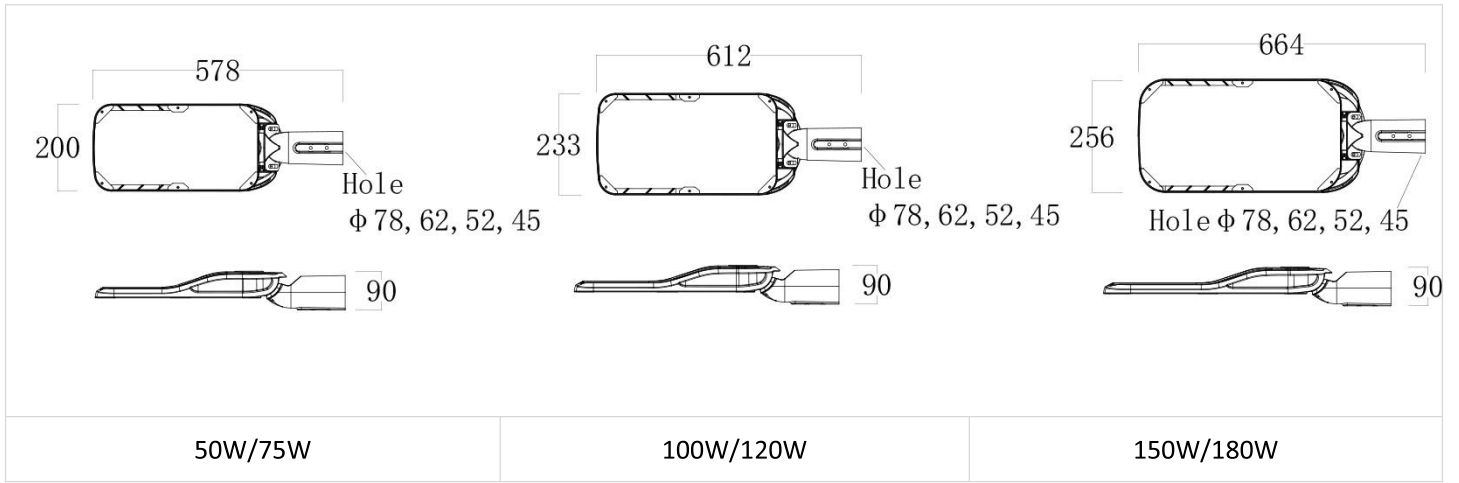

Photometry

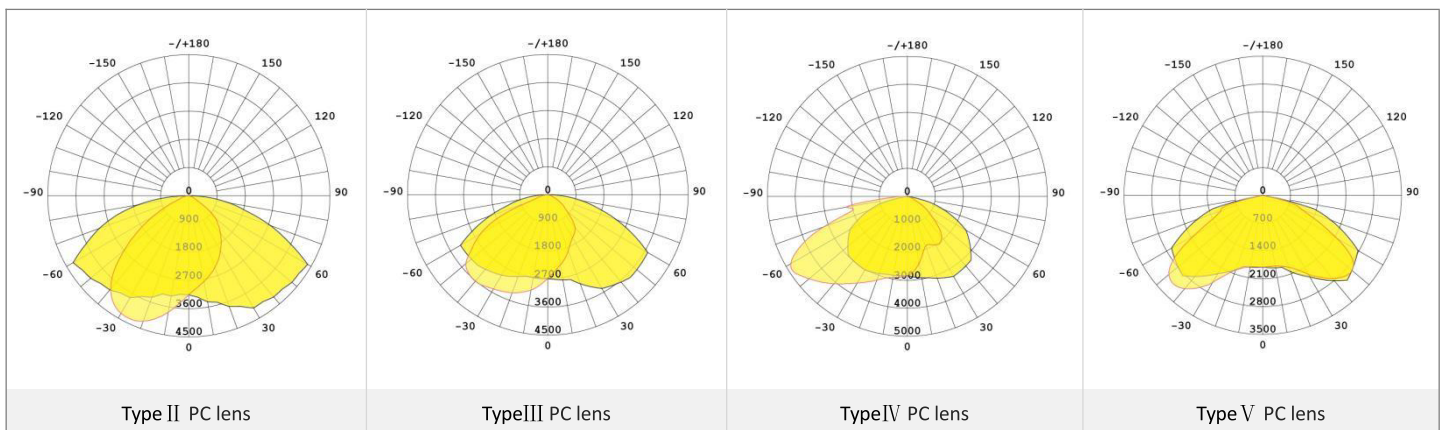

SL50 Street Light

Product Data

Model	SPS50-SL50	SPS75-SL50	SPS100-SL50	SPS120-SL50	SPS150-SL50	SPS180-SL50	SPS200-S50	SPS240-SL50
Wattage	50W	75W	100W	120W	150W	180W	200W	240W
Lumen Output	7500lm	11250lm	15000lm	18000lm	22500lm	27000lm	30000lm	36000lm
Luminous Efficacy	150lm/W (150~160lm/W)							
CCT	3000K/4000K/5000K/5700K/6500K							
CRI	Ra≥70							
PF	> 0.9							
Input Voltage	100-277 VAC							
Housing Color	Light grey							
Housing Material	Aluminum(ADC12), lens+temper glass							
Operating Temperature	-30°C to +45°C							
IP Level	IP66							
Lifespan	50,000 hours							
Warranty	5 years							

Packaging

Model	PCS/CTN	Net Weight	Gross weight	Volumetric Weight	CBM
SPS50-SL50	1	2.95kg	3.46kg	4.9kg	630×240×125mm ≈ 0.019 ³
SPS75-SL50	1	3.25kg	3.77kg	4.9kg	630×240×125mm ≈ 0.019 ³
SPS100-SL50	1	3.85kg	4.83kg	5.63kg	650×270×125mm ≈ 0.022 ³
SPS120-SL50	1	4.15kg	5.13kg	5.63kg	650×270×125mm ≈ 0.022 ³
SPS150-SL50	2	4.66kg	10.03kg	9.96kg	710×190×305mm ≈ 0.041 ³
SPS180-SL50	2	4.80kg	10.31kg	9.96kg	710×190×305mm ≈ 0.041 ³
SPS200-SL50	1	5.88kg	6.69kg	8.14kg	760×340×125mm ≈ 0.032 ³
SPS240-SL50	1	5.95kg	6.76kg	8.14kg	760×340×125mm ≈ 0.032 ³

SL50 Street Light

Installation

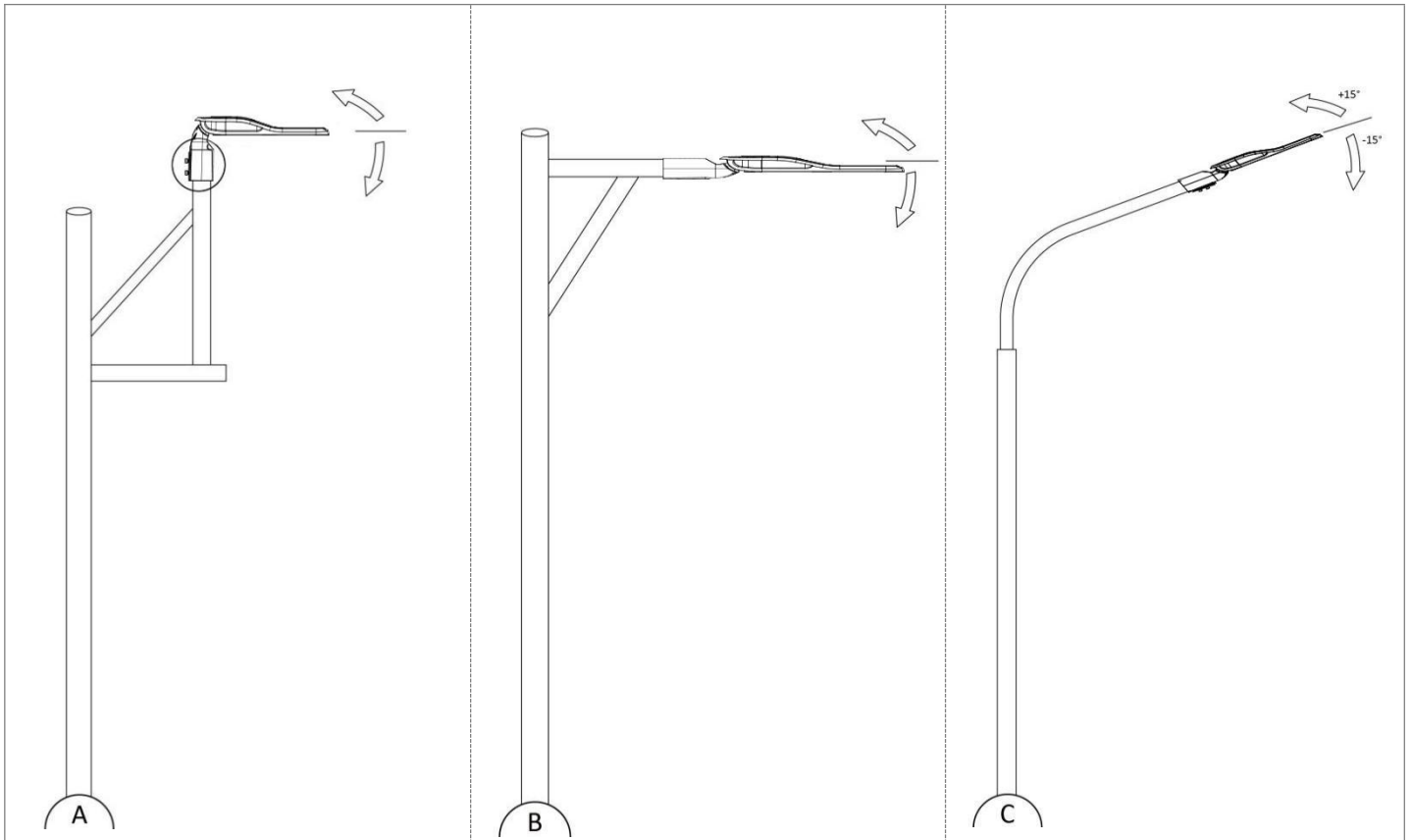

ANSI

White cable for "N"

Green for ground wire

Black cable is for "L"

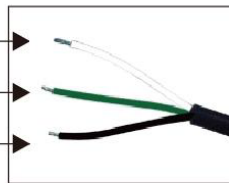

EN

Blue cable for "N"

Brown cable is for "L"



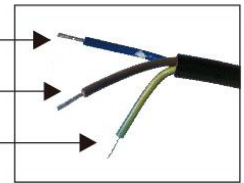





Green/Yellow for ground wire



※ Note: If the lamp be used outside, please keep the connector water-proof.

SL50 Street Light

Shorting cap & photocell

LED fixtures match	photocell options		controller base		JL-208	JL-205C	JL207C	JL241C	JL251C	JL254C	Gateway box(P/V)
					"shorting cap Φ73X41MM IP66"	"Analog electronic control three-wire 6Lx ON 50Lx OFF 10s delay Φ84X66MM AC100-277V "	"Digital electronic control three-wire 16Lx ON 24Lx OFF 5-20s delay Φ84X66M AC100-277 V"	"0-10V dimming seven-wire 50Lx ON 50Lx OFF 10s delay Φ84X66MM AC100-277V "	"Dali dimming seven-wire 50Lx ON 50Lx OFF 10s delay Φ84X86MM AC100-277V "	"Zigbee control(need work with gateway box) Dali dimming Midnight Dimming LED Decay Compensati on seven-wire 50Lx ON 50Lx OFF 5s delay Φ84X86MM AC100-277V "	remote control by using a gateway box connected to a smart phone(iOS/An driod) with blue tooth communicati on, while connected to the smart control(JL-25 4C) with Zigbee communicati on
											
"SL27,SL29,SL30, SL32,SL40 series non-dimmable"	JL-200X		"S:Φ65X38.5MM,0-480VAC, AWG18#:10A, AWG14#:15A, ULapproval, 3-wire 150MM (match non-dimming)"	✓	✓	✓					
"SL27,SL29,SL30, SL32,SL40 series 0-10V dimmable"	JL-240XB		"S:Φ65X40MM,0-480VAC, AWG18#: 10A, AWG14:15A, ULapproval, 5-wire 150MM (match 0-10V dimming)"	✓			✓				
"SL27,SL29,SL30, SL32,SL40 series 0-10V/ Dali dimmable"	JL-240XA		"S:Φ65X40MM,0-480VAC, AWG18#:10A, AWG14#:15A, ULapproval,7-wire 150MM (match 0-10V/dali dimming)"	✓	✓	✓	✓	✓	✓		